

[Back to index](#)

EQUIPMENT INFORMATION SHEET

Notes and abbreviations

Center Aisle

[Link to PDF file](#)

ITEM #	QTY		MODEL #	ITEM DESCRIPTION	MANUFACTURER	CONTRACTOR INFORMATION			REMARKS	UTILITY INFORMATION		
	EXT	NEW				I	F	C		ELECTRICAL	MECHANICAL: SUPPLY	MECHANICAL: WASTE
CA106.2				4'X4' Battery Rack	Vendor Provided	FC			Set in place.			

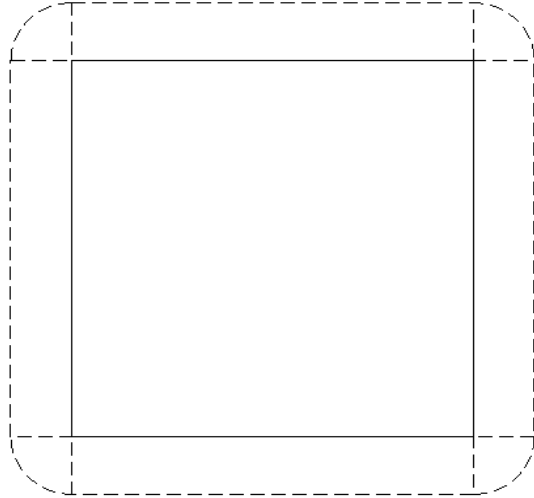

EQUIPMENT CELL INFORMATION

Date created:	8/11/2011
Date revised:	
Cell library:	Layout-Hardlines
Cell name(s):	HLCA106.2

Special CAD Instructions:

ITEM NUMBER:	CA106.2
--------------	---------

Meijer Grocery Island

Meijer Battery Grocery Island

4' x 2' Island

MEIGROISL 0-39800-10998-9

CARTON DIMENSIONS: H- 65 1/2 " x W- 57 " x D- 32 "

SHIPPING WEIGHT: 276 lbs.

PALLET TI x HI: 1 unit per pallet

DISPLAY DIMENSIONS: H-60" x W-51.38" x D-25.15"

PEG HOOK LENGTH: Meijer Style 2-part 6" Scan Loop Hooks w/ Tag

SHELVES: 16" depth

FACINGS (based on standard cards)

CUSTOM



THE INFORMATION CONTAINED IN THIS DRAWING IS THE SOLE PROPERTY OF TRANS WORLD. ANY REPRODUCTION IN PART OR WHOLE WITHOUT THE WRITTEN PERMISSION OF TRANS WORLD MARKETING IS PROHIBITED.
 © COPYRIGHT 2010 TRANS WORLD MARKETING, INC. ALL RIGHTS RESERVED.

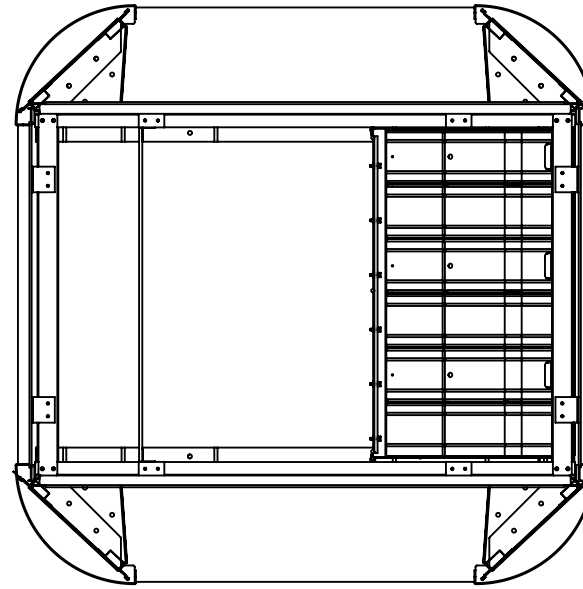

LID REMOVED ONLY FOR THE PURPOSE OF ILLUSTRATION

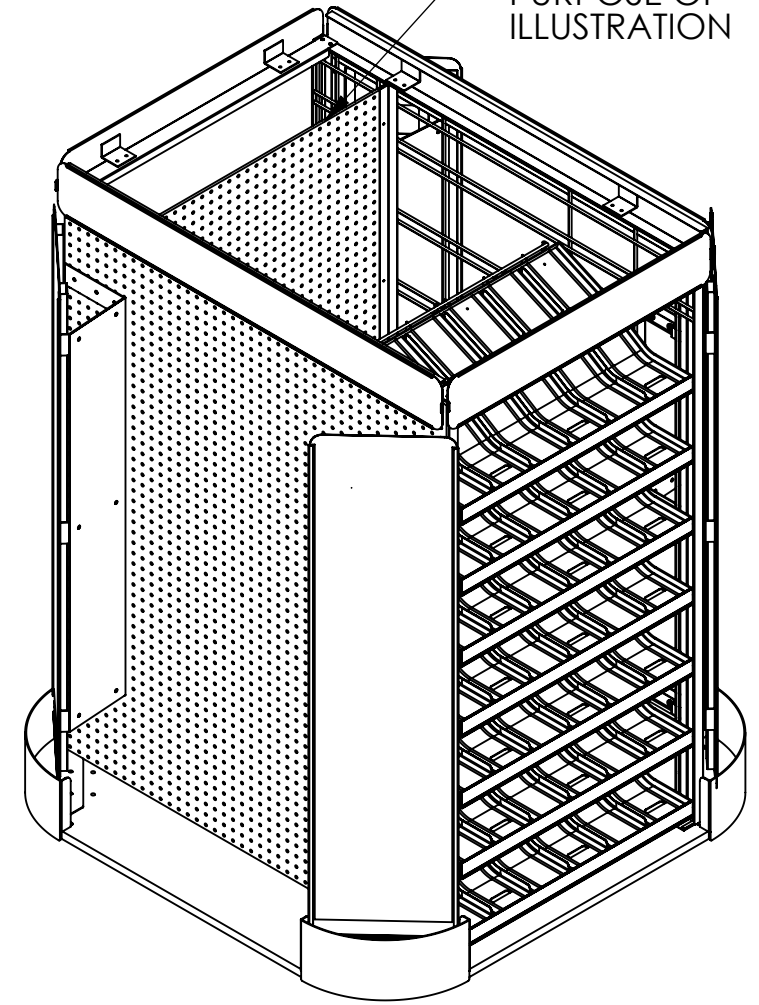

28.06
FLAT WIDTH

23.00
PEG AREA

27.50
FLAT WIDTH

27.00
PEG AREA

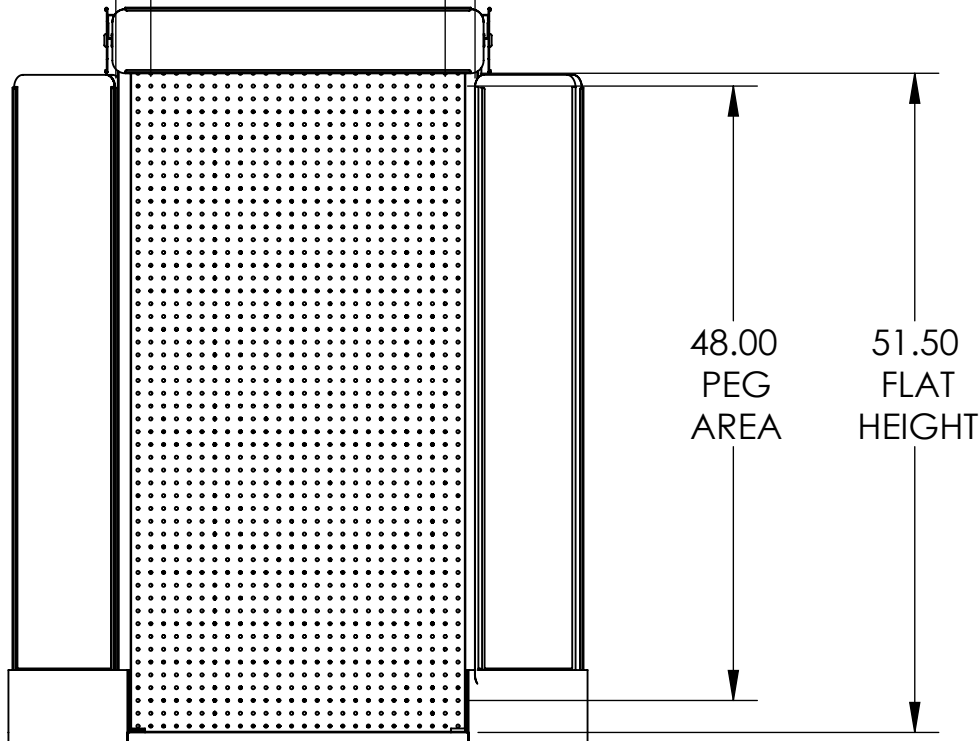

48.00
PEG AREA

51.50
FLAT HEIGHT

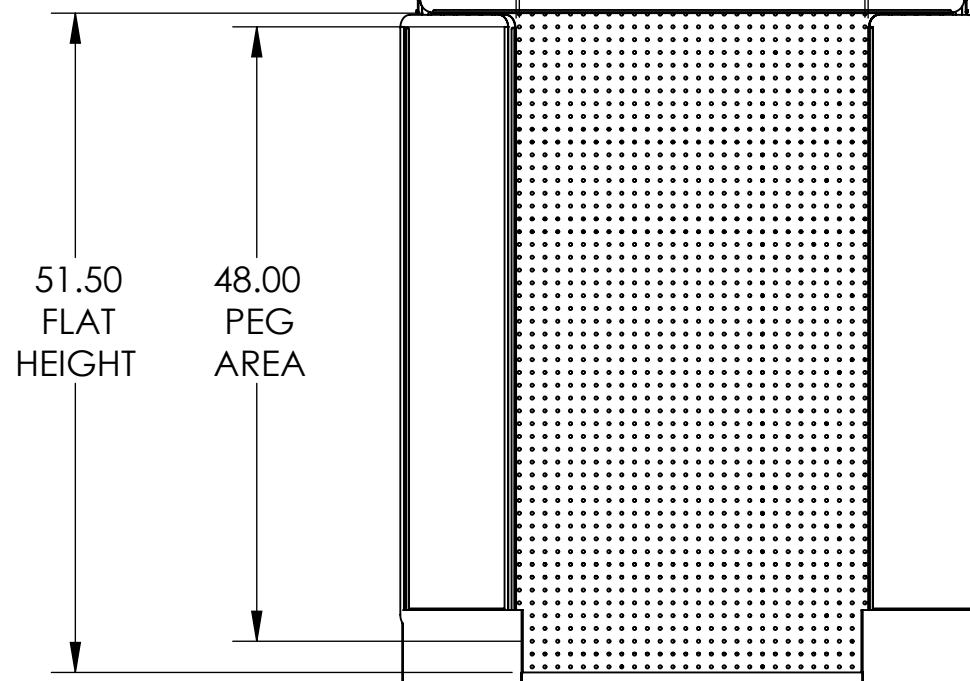

51.50
FLAT HEIGHT

48.00
PEG AREA

CAD FILE: Z:\KKENNY\energizer\05819R12 MEIJER E4 ISLAND\05819-1000 PEG AREA MEIJER E4 ISLAND

7/30/2010 2:03:44 PM

REV A

05819-1000

MEIJER E4 ISLAND

UNLESS OTHERWISE SPECIFIED: NO CHANGES ARE ALLOWED WITHOUT WRITTEN APPROVAL FROM TWM ENGINEERING, REGARDLESS OF WHETHER OR NOT SUCH CHANGES AFFECT CHARACTERISTICS SPECIFIED. <i>FIRST SAMPLES MUST BE 100% INSPECTED BY VENDOR AND SUBMITTED TO TWM ENGINEERING ALONG WITH A MARKED-UP PRINT OF ALL EXCEPTIONS TO SPECIFICATIONS.</i>		 TRANS WORLD MARKETING 360 MURRAY HILL PARKWAY EAST RUTHERFORD, NJ 07073	
TOLERANCES ANGLES: X° ± 1° DECIMALS: .XX ± .02, .XXX ± .010 FRACTIONS: XX/X ± 1/32		CLIENT: ENERGIZER	
MATERIAL SEE COMPONENT DWG		PROJECT: MEIJER E4 ISLAND	
FINISH SEE COMPONENT DWG		DESCRIPTION: MEIJER E4 ISLAND	
DO NOT SCALE DRAWING	SCALE 1:15	SIZE B	ENGR. ENGR.PART# 05819-1000 REV A SHEET 1 OF 1

THE INFORMATION CONTAINED IN THIS DRAWING IS THE SOLE PROPERTY OF TRANS WORLD. ANY REPRODUCTION IN PART OR WHOLE WITHOUT THE WRITTEN PERMISSION OF TRANS WORLD MARKETING IS PROHIBITED.
 © COPYRIGHT 2009 TRANS WORLD MARKETING, INC. ALL RIGHTS RESERVED.

REVISIONS			
REV	DATE	DESCRIPTION	AR/CO
A			

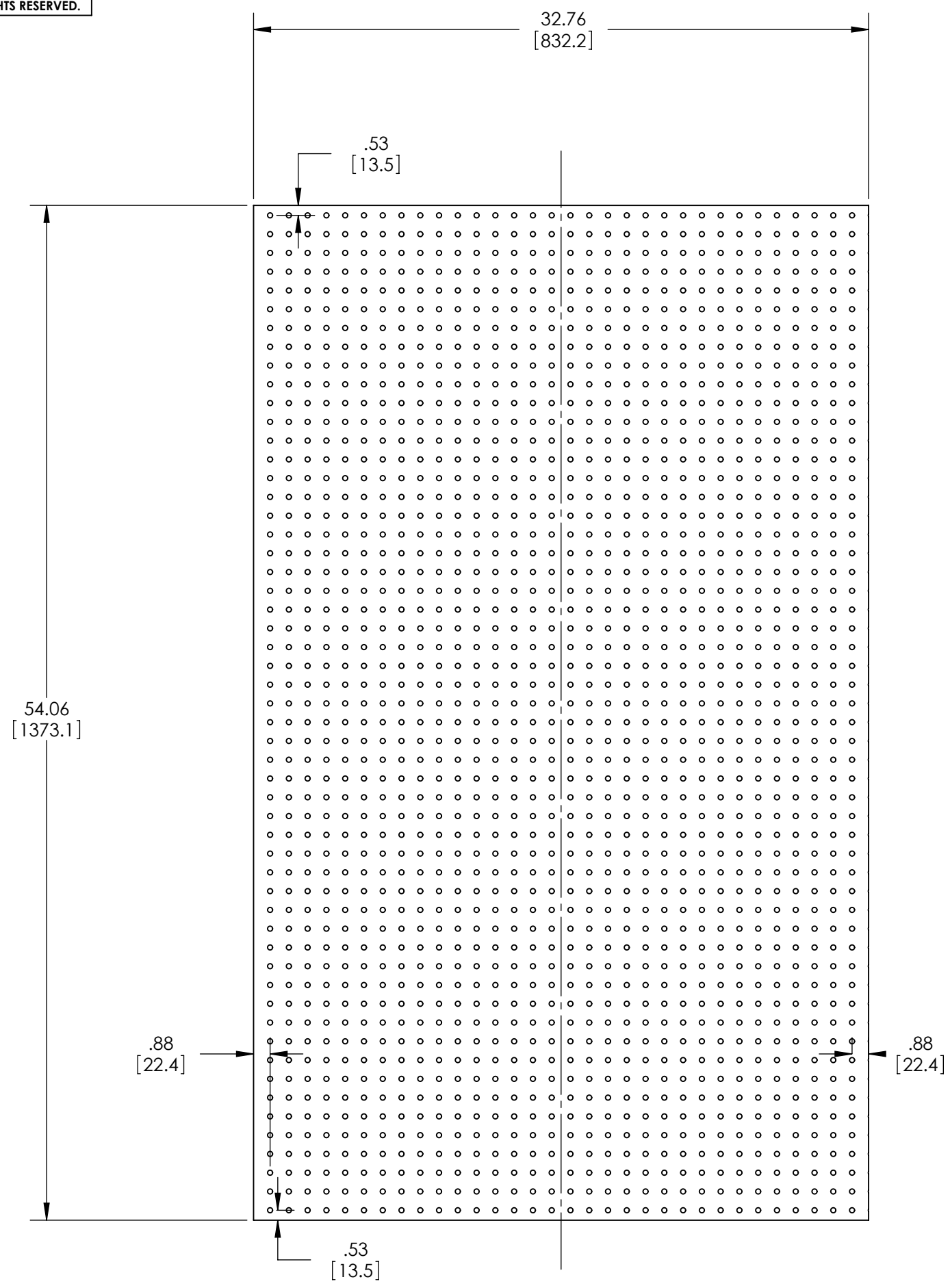

BLACK 2 SIDES

REV A

CAD FILE: C:\Documents and Settings\eherry\Desktop\07497rev8 Meijer Grocery Island\new unit\ middle peg

10/4/2010 2:35:11 PM

UNLESS OTHERWISE SPECIFIED: NO CHANGES ARE ALLOWED WITHOUT WRITTEN APPROVAL FROM TWM ENGINEERING, REGARDLESS OF WHETHER OR NOT SUCH CHANGES AFFECT CHARACTERISTICS SPECIFIED. FIRST SAMPLES MUST BE 100% INSPECTED BY VENDOR AND SUBMITTED TO TWM ENGINEERING ALONG WITH A MARKED-UP PRINT OF ALL EXCEPTIONS TO SPECIFICATIONS.		 TRANS WORLD MARKETING 360 MURRAY HILL PARKWAY EAST RUTHERFORD, NJ 07073	
TOLERANCES ANGLES: X° ± 1° DECIMALS: .XX ± .02, .XXX ± .010 FRACTIONS: X/X ± 1/32		CLIENT:	
MATERIAL:		PROJECT:	
FINISH:		DESCRIPTION:	
DO NOT SCALE DRAWING		ENGR. PART#	REV A SHEET 1 OF 1